

50 Hz



Construction

- The VCT pumps are non self priming, horizontal, two-stage, centrifugal pumps.
- Motor and pump are close coupled in a convenient and compact design for quick installation in limited space.
- The pump is fitted with a maintenance-free, mechanical shaft seal.
- The pumps have axial suction port and radial discharge port.

Applications

- For clean liquids without abrasives, which are non-aggressive for the pump materials. (solids content up to 0.2%)
- For water supply.
- For heating, cooling, air-conditioning and circulation plants.
- For civil and industrial applications.
- As pressure boosting pumps for central water systems.
- For irrigation.
- For circulation plants.
- For washing with a jet of water.

Operating Conditions

- Liquid temperature up to 90°C.
- Ambient temperature up to 50°C.
- Total suction lift up to 7 m.
- Continuous duty.

Motor

- 2-pole induction motor, 50 Hz (n = 2900 RPM)
- Single phase 230V +5% -15% with thermal protection.
- Insulation class B.
- Protection IP 44.
- Constructed in accordance with IEC 34.
- Available in 60 Hz.

Special Features on Request

- Other voltages.
- Available in three phase.
- Available stainless steel or brass impeller.
- Special mechanical seal.
- Higher liquid or ambient temperatures.

Direction of rotation

Clockwise as seen from the motor rear end.

Materials

Pos.	Component	Material
1	Volute Cover	CI.GR.FG.200
2	Impeller-1	Brass
3	Volute Gasket	Rubber
4	Middle Plate	CI.GR.FG.200
5	Impeller-2	Brass
6	Volute	CI.GR.FG.200
7	Mechanical Seal	CI.GR.FG.200
8	Water Thrower	Rubber
9	Circlip	Sp. Steel
10	Key	M.S.

Sectional drawing

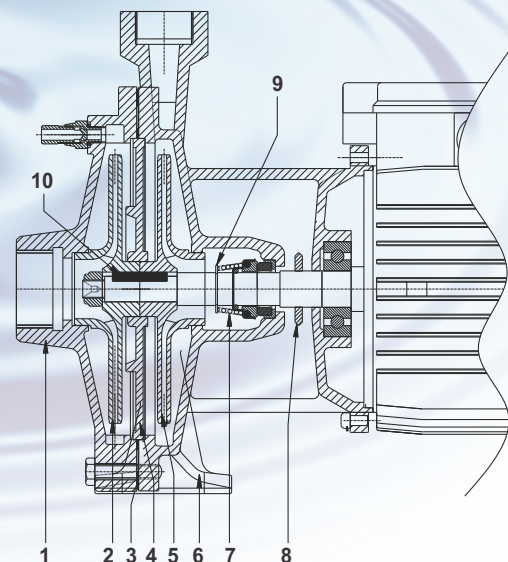

Performance Curve

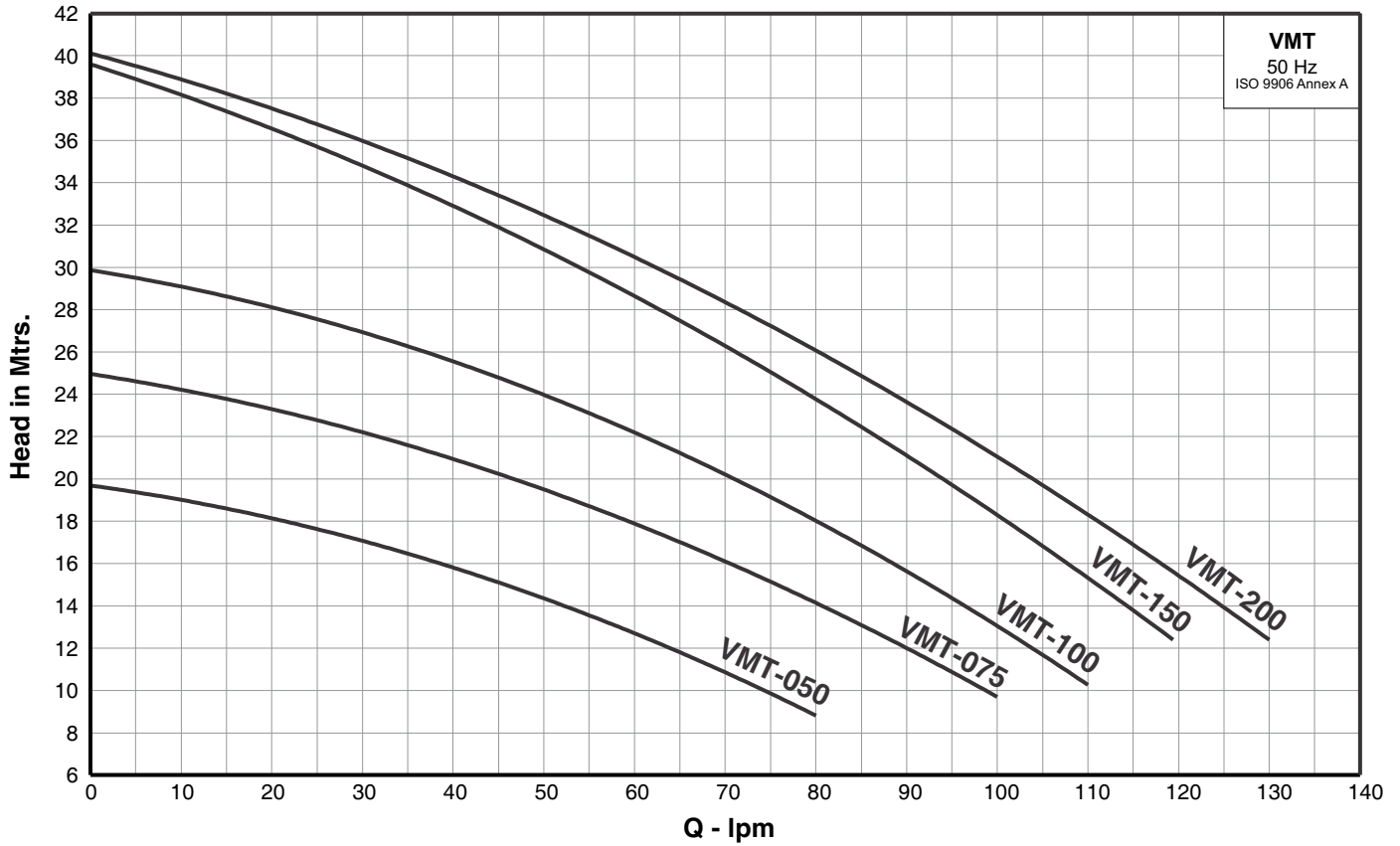

Performance data

Pump type	Motor power		Pipe Size [mm]	Head in Meters														
	kW	HP		10	12	14	16	18	20	22	24	26	28	30	32	34	36	38
VMT 050	0.37	0.5	32x25	4500	3900	3000	2400	1200	-	-	-	-	-	-	-	-	-	-
VMT 075	0.55	0.75	32x25	6000	5400	4800	4200	3600	2700	1800	600	-	-	-	-	-	-	-
VMT 100	0.75	1	32x25	6600	6300	5700	5400	4800	4200	3600	3000	2100	1200	-	-	-	-	-
VMT 150	1.1	1.5	32x25	-	7200	6900	6600	6000	5700	5100	4800	4200	3900	3300	2700	2100	1500	600
VMT 200	1.5	2	32x25	-	7800	7500	7200	6600	6300	5700	5400	4800	4200	3600	3000	2400	1800	1200