

Technical Data

Vertical multistage centrifugal pumps

LCR 45

Performance Chart

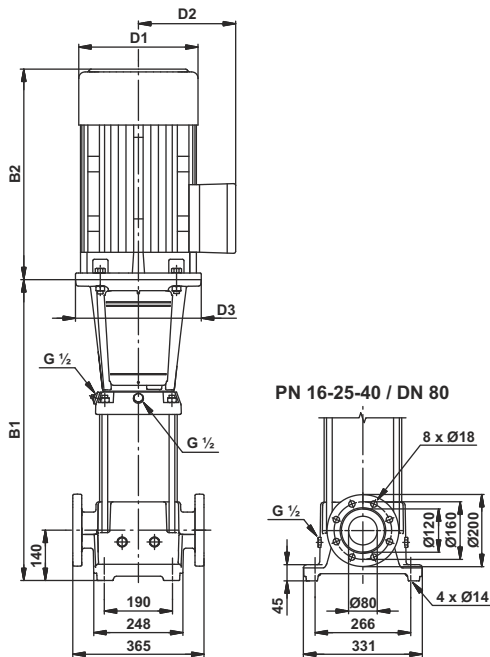

Pump Type	H.P.	kW	Q l/min m ³ /h	n = 2900 rpm					
				366.7	500.0	666.7	750.0	833.3	916.7
				22.0	30.0	40.0	45.0	50.0	55.0
LCR 45/1-1	4.00	3.00	H mts.	20	20	17	15	13	11
LCR 45/1	5.50	4.00		25	24	21	20	18	16
LCR 45/2-2	7.50	5.50		41	39	35	31	27	22
LCR 45/2	10.0	7.50		50	48	43	40	36	32
LCR 45/3-2	15.0	11.0		67	64	57	52	46	39
LCR 45/3	15.0	11.0		76	72	65	60	54	48
LCR 45/4-2	20.0	15.0		93	88	79	73	64	56
LCR 45/4	20.0	15.0		100	95	86	80	72	64
LCR 45/5-2	25.0	18.5		119	113	101	93	84	74
LCR 45/5	25.0	18.5		126	120	108	101	91	80
LCR 45/6-2	30.0	22.0		145	138	124	114	103	90
LCR 45/6	30.0	22.0		152	145	130	120	108	97
LCR 45/7-2	40.0	30.0		170	163	148	137	124	109
LCR 45/7	40.0	30.0		178	171	155	145	132	117
LCR 45/8-2	40.0	30.0		196	187	169	157	142	125
LCR 45/8	40.0	30.0		203	194	175	164	150	133
LCR 45/9-2	40.0	30.0		220	211	191	177	160	142
LCR 45/9	50.0	37.0		229	220	199	185	168	150
LCR 45/10-2	50.0	37.0		246	235	213	198	180	159
LCR 45/10	50.0	37.0		254	242	220	206	188	167
LCR 45/11-2	60.0	45.0	277	263	238	221	201	177	
LCR 45/11	60.0	45.0	285	272	247	230	210	187	
LCR 45/12-2	60.0	45.0	303	289	261	243	220	195	
LCR 45/12	60.0	45.0	313	297	269	251	229	204	
LCR 45/13-2	60.0	45.0	328	314	283	263	239	212	

Dimensions & Weights of LCR Pump

Pump type	Dimensions [mm]					Net weight [kg]	Gross weight [kg]	Gross volume [m ³]
	DIN flange		D1	D2	D3			
	B1	B1+B2						
LCR 45/1-1	559	863	194	140	-	80.0	138.0	0.3745
LCR 45/1	559	909	220	150	158	91.0	149.0	0.3745
LCR 45/2-2	639	1049	262	177	298	108.0	166.0	0.3745
LCR 45/2	639	1049	262	177	298	110.0	168.0	0.3745
LCR 45/3-2	829	1371	304	225	350	149.0	207.0	0.3745
LCR 45/3	829	1371	304	225	350	149.0	219.0	0.4495
LCR 45/4-2	909	1451	304	225	350	169.0	239.0	0.4495
LCR 45/4	909	1451	304	225	350	169.0	239.0	0.4495
LCR 45/5-2	989	1531	304	225	350	204.0	274.0	0.4495
LCR 45/5	989	1531	304	225	350	204.0	274.0	0.4495
LCR 45/6-2	1069	1679	363	262	350	240.0	310.0	0.4495
LCR 45/6	1069	1679	363	262	350	240.0	310.0	0.4495
LCR 45/7-2	1149	1795	415	300	400	321.0	404.0	0.5370
LCR 45/7	1149	1795	415	300	400	321.0	404.0	0.5370
LCR 45/8-2	1229	1875	415	300	400	336.0	419.0	0.5370
LCR 45/8	1229	1875	415	300	400	336.0	419.0	0.5370
LCR 45/9-2	1309	1955	415	300	400	341.0	424.0	0.5370
LCR 45/9	1309	2012	415	300	400	361.0	444.0	0.5370
LCR 45/10-2	1389	2092	415	300	400	366.0	463.0	0.6245
LCR 45/10	1389	2092	415	300	400	366.0	463.0	0.6245
LCR 45/11-2	1469	2178	442	325	450	478.0	575.0	0.6245
LCR 45/11	1469	2178	442	325	450	478.0	575.0	0.6245
LCR 45/12-2	1549	2258	442	325	450	483.0	580.0	0.6245
LCR 45/12	1549	2258	442	325	450	483.0	580.0	0.6245
LCR 45/13-2	1629	2338	442	325	450	488.0	585.0	0.6245

Performance Curves

Vertical multistage centrifugal pumps

LCR 45

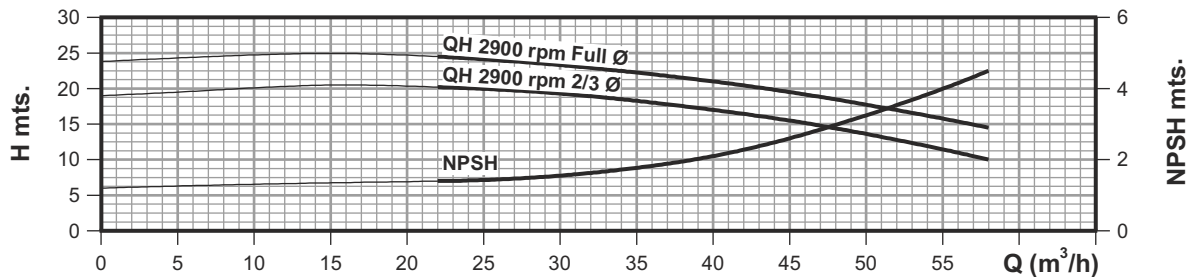
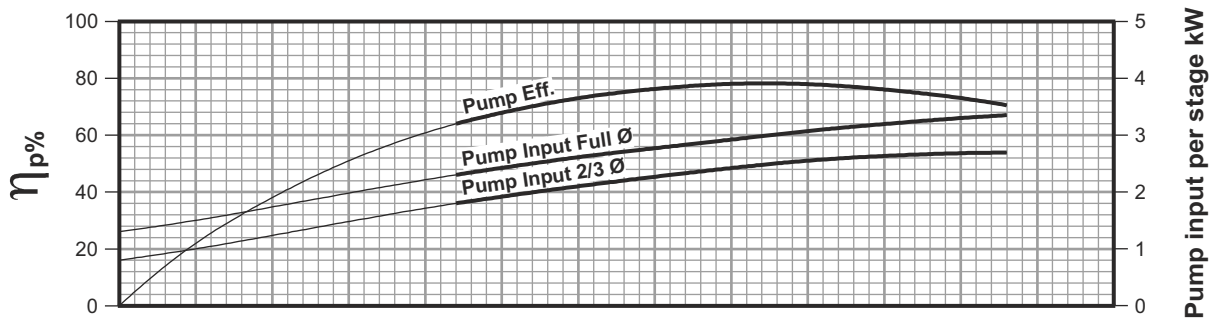
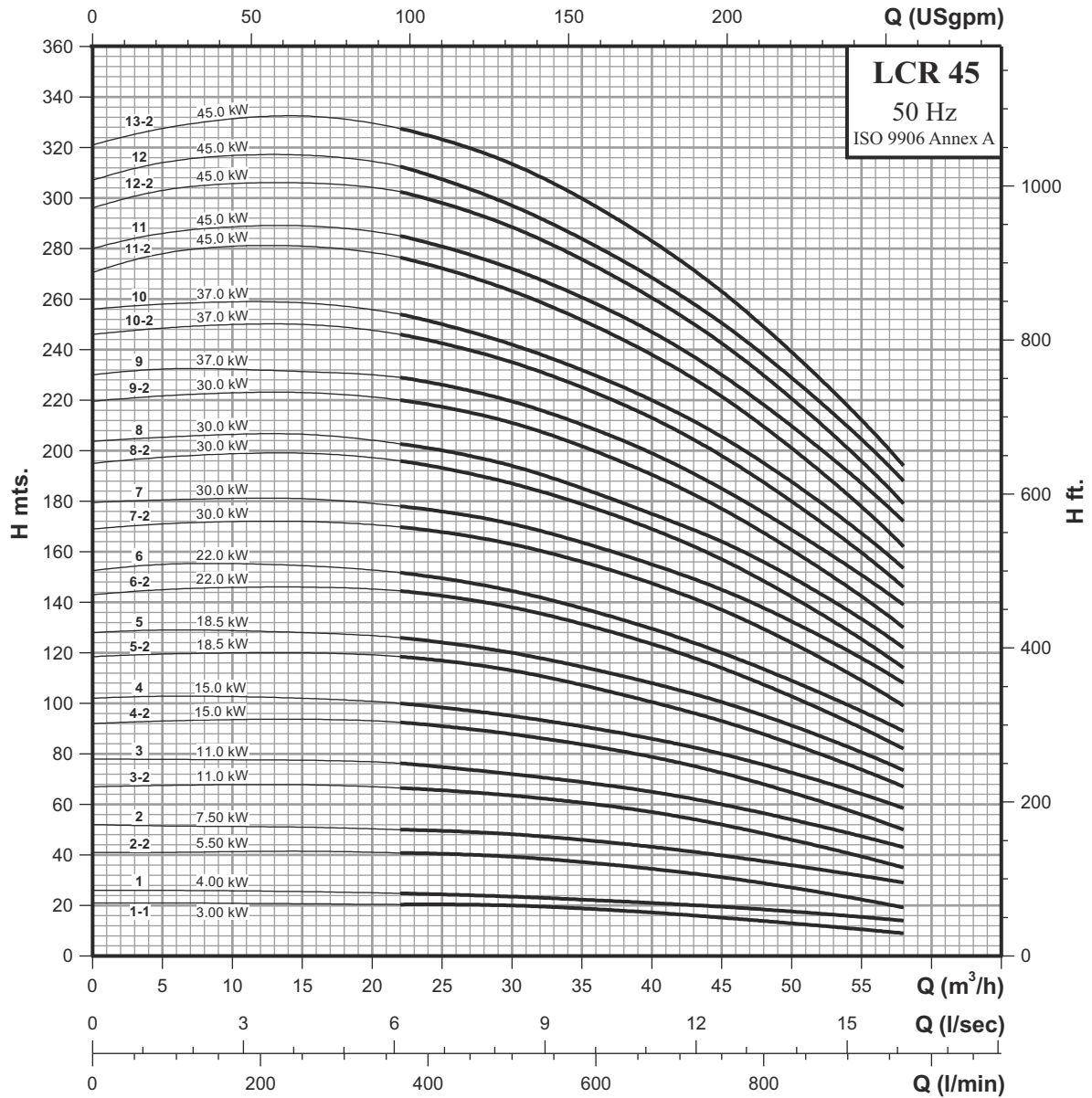

Technical Data

Vertical multistage centrifugal pumps

LCRI, LCRN 45

Performance Chart

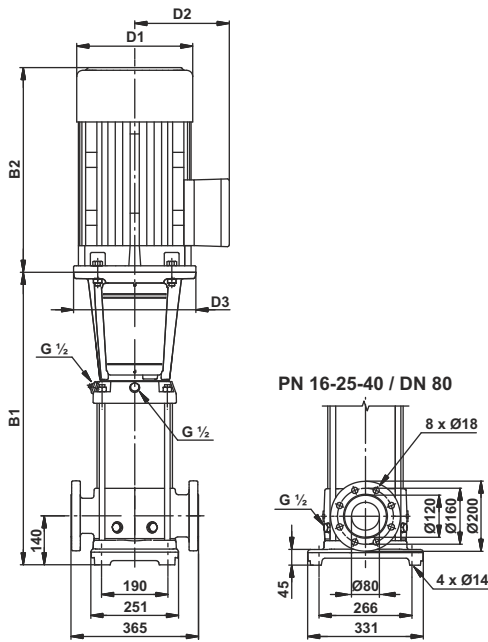

Pump Type	H.P.	kW	Q l/min m ³ /h	n = 2900 rpm					
				366.7	500.0	666.7	750.0	833.3	916.7
				22.0	30.0	40.0	45.0	50.0	55.0
LCRI, LCRN 45/1-1	4.00	3.00	H mts.	20	20	17	15	13	11
LCRI, LCRN 45/1	5.50	4.00		25	24	21	20	18	16
LCRI, LCRN 45/2-2	7.50	5.50		41	39	35	31	27	22
LCRI, LCRN 45/2	10.0	7.50		50	48	43	40	36	32
LCRI, LCRN 45/3-2	15.0	11.0		67	64	57	52	46	39
LCRI, LCRN 45/3	15.0	11.0		76	72	65	60	54	48
LCRI, LCRN 45/4-2	20.0	15.0		93	88	79	73	64	56
LCRI, LCRN 45/4	20.0	15.0		100	95	86	80	72	64
LCRI, LCRN 45/5-2	25.0	18.5		119	113	101	93	84	74
LCRI, LCRN 45/5	25.0	18.5		126	120	108	101	91	80
LCRI, LCRN 45/6-2	30.0	22.0		145	138	124	114	103	90
LCRI, LCRN 45/6	30.0	22.0		152	145	130	120	108	97
LCRI, LCRN 45/7-2	40.0	30.0		170	163	148	137	124	109
LCRI, LCRN 45/7	40.0	30.0		178	171	155	145	132	117
LCRI, LCRN 45/8-2	40.0	30.0		196	187	169	157	142	125
LCRI, LCRN 45/8	40.0	30.0		203	194	175	164	150	133
LCRI, LCRN 45/9-2	40.0	30.0		220	211	191	177	160	142
LCRI, LCRN 45/9	50.0	37.0		229	220	199	185	168	150
LCRI, LCRN 45/10-2	50.0	37.0		246	235	213	198	180	159
LCRI, LCRN 45/10	50.0	37.0		254	242	220	206	188	167
LCRI, LCRN 45/11-2	60.0	45.0	277	263	238	221	201	177	
LCRI, LCRN 45/11	60.0	45.0	285	272	247	230	210	187	
LCRI, LCRN 45/12-2	60.0	45.0	303	289	261	243	220	195	
LCRI, LCRN 45/12	60.0	45.0	313	297	269	251	229	204	
LCRI, LCRN 45/13-2	60.0	45.0	328	314	283	263	239	212	

Dimensions & Weights of LCRI, LCRN Pump

Pump type	Dimensions [mm]					Net weight [kg]	Gross weight [kg]	Gross volume [m ³]
	DIN flange		D1	D2	D3			
	B1	B1+B2						
LCRI, LCRN 45/1-1	559	863	194	140	-	80.0	138.0	0.3745
LCRI, LCRN 45/1	559	909	220	150	158	91.0	149.0	0.3745
LCRI, LCRN 45/2-2	639	1049	262	177	298	108.0	166.0	0.3745
LCRI, LCRN 45/2	639	1049	262	177	300	110.0	168.0	0.3745
LCRI, LCRN 45/3-2	829	1371	304	225	350	149.0	207.0	0.3745
LCRI, LCRN 45/3	829	1371	304	225	350	149.0	219.0	0.4495
LCRI, LCRN 45/4-2	909	1451	304	225	350	169.0	239.0	0.4495
LCRI, LCRN 45/4	909	1451	304	225	350	169.0	239.0	0.4495
LCRI, LCRN 45/5-2	989	1531	304	225	350	204.0	274.0	0.4495
LCRI, LCRN 45/5	989	1531	304	225	350	204.0	274.0	0.4495
LCRI, LCRN 45/6-2	1069	1679	363	262	350	240.0	310.0	0.4495
LCRI, LCRN 45/6	1069	1679	363	262	350	240.0	310.0	0.4495
LCRI, LCRN 45/7-2	1149	1795	415	300	400	321.0	404.0	0.5370
LCRI, LCRN 45/7	1149	1795	415	300	400	321.0	404.0	0.5370
LCRI, LCRN 45/8-2	1229	1875	415	300	400	336.0	419.0	0.5370
LCRI, LCRN 45/8	1229	1875	415	300	400	336.0	419.0	0.5370
LCRI, LCRN 45/9-2	1309	1955	415	300	400	341.0	424.0	0.5370
LCRI, LCRN 45/9	1309	2012	415	300	400	361.0	444.0	0.5370
LCRI, LCRN 45/10-2	1389	2092	415	300	400	366.0	463.0	0.6245
LCRI, LCRN 45/10	1389	2092	415	300	400	366.0	463.0	0.6245
LCRI, LCRN 45/11-2	1469	2178	442	325	450	478.0	575.0	0.6245
LCRI, LCRN 45/11	1469	2178	442	325	450	478.0	575.0	0.6245
LCRI, LCRN 45/12-2	1549	2258	442	325	450	483.0	580.0	0.6245
LCRI, LCRN 45/12	1549	2258	442	325	450	483.0	580.0	0.6245
LCRI, LCRN 45/13-2	1629	2338	442	325	450	488.0	585.0	0.6245

Performance Curves

Vertical multistage centrifugal pumps

LCRI, LCRN 45

