

Technical Data

Vertical multistage centrifugal pumps

LCR 32

Performance Chart

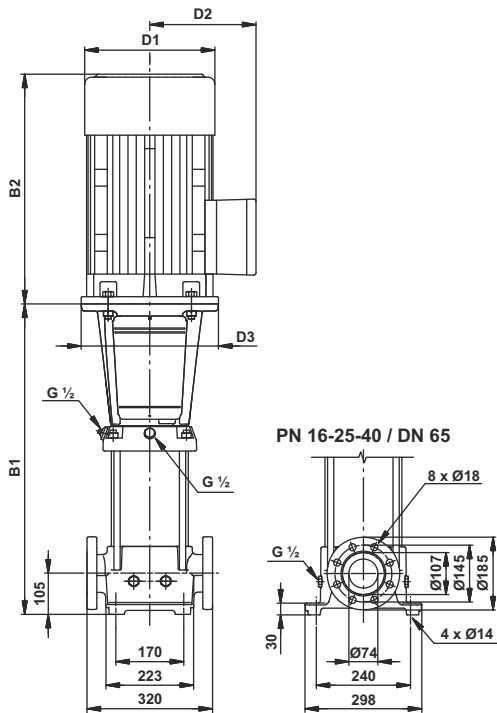

Pump Type	H.P.	kW	Q l/min m ³ /h	n = 2900 rpm					
				250.0	333.3	400.0	466.7	533.3	600.0
				15.0	20.0	24.0	28.0	32.0	36.0
LCR 32/1-1	2.00	1.50	H mts.	16	15	13	12	10	8
LCR 32/1	3.00	2.20		19	18	16	15	13	11
LCR 32/2-2	4.00	3.00		31	29	26	24	21	17
LCR 32/2	5.50	4.00		38	35	33	31	27	23
LCR 32/3-2	7.50	5.50		51	48	44	41	36	30
LCR 32/3	7.50	5.50		57	54	51	47	42	36
LCR 32/4-2	10.0	7.50		69	66	61	56	50	42
LCR 32/4	10.0	7.50		76	72	68	63	56	49
LCR 32/5-2	15.0	11.0		89	85	80	74	66	56
LCR 32/5	15.0	11.0		96	91	85	79	72	63
LCR 32/6-2	15.0	11.0		107	102	96	89	79	69
LCR 32/6	15.0	11.0		114	109	103	96	86	76
LCR 32/7-2	20.0	15.0		127	120	113	105	94	82
LCR 32/7	20.0	15.0		133	127	120	112	102	90
LCR 32/8-2	20.0	15.0		146	138	130	120	108	94
LCR 32/8	20.0	15.0		151	143	135	126	113	100
LCR 32/9-2	25.0	18.5		165	157	148	137	123	108
LCR 32/9	25.0	18.5		172	163	153	143	130	115
LCR 32/10-2	25.0	18.5		184	175	165	153	137	120
LCR 32/10	25.0	18.5		191	182	171	159	144	127
LCR 32/11-2	30.0	22.0	204	194	183	170	153	134	
LCR 32/11	30.0	22.0	210	200	188	176	159	141	
LCR 32/12-2	30.0	22.0	223	212	200	187	168	148	
LCR 32/12	30.0	22.0	229	217	206	193	176	155	
LCR 32/13-2	40.0	30.0	244	233	221	208	188	167	
LCR 32/13	40.0	30.0	250	239	227	213	194	172	
LCR 32/14-2	40.0	30.0	263	251	237	221	200	177	
LCR 32/14	40.0	30.0	270	257	244	228	208	184	

Dimensions & Weights of LCR Pump

Pump type	Dimensions [mm]					Net weight [kg]	Gross weight [kg]	Gross volume [m ³]
	DIN flange		D1	D2	D3			
	B1	B1+B2						
LCR 32/1-1	505	783	165	130	135	61.0	119.0	0.3745
LCR 32/1	505	783	165	130	135	62.0	120.0	0.3745
LCR 32/2-2	575	879	194	140	-	76.0	134.0	0.3745
LCR 32/2	575	925	220	150	158	87.0	145.0	0.3745
LCR 32/3-2	645	1055	262	177	298	107.0	165.0	0.3745
LCR 32/3	645	1055	262	177	298	107.0	165.0	0.3745
LCR 32/4-2	715	1125	262	177	298	117.0	175.0	0.3745
LCR 32/4	715	1125	262	177	298	117.0	175.0	0.3745
LCR 32/5-2	895	1437	304	225	350	155.0	225.0	0.4495
LCR 32/5	895	1437	304	225	350	155.0	225.0	0.4495
LCR 32/6-2	965	1507	304	225	350	158.0	228.0	0.4495
LCR 32/6	965	1507	304	225	350	158.0	228.0	0.4495
LCR 32/7-2	1035	1577	304	225	350	175.0	245.0	0.4495
LCR 32/7	1035	1577	304	225	350	175.0	245.0	0.4495
LCR 32/8-2	1105	1647	304	225	350	178.0	248.0	0.4495
LCR 32/8	1105	1647	304	225	350	178.0	248.0	0.4495
LCR 32/9-2	1175	1717	304	225	350	211.0	294.0	0.5370
LCR 32/9	1175	1717	304	225	350	211.0	294.0	0.5370
LCR 32/10-2	1245	1787	304	225	350	214.0	297.0	0.5370
LCR 32/10	1245	1787	304	225	350	214.0	297.0	0.5370
LCR 32/11-2	1315	1925	363	262	350	250.0	333.0	0.5370
LCR 32/11	1315	1925	363	262	350	250.0	333.0	0.5370
LCR 32/12-2	1385	1995	363	262	350	254.0	337.0	0.5370
LCR 32/12	1385	1995	363	262	350	254.0	337.0	0.5370
LCR 32/13-2	1455	2101	415	300	400	322.0	419.0	0.6245
LCR 32/13	1455	2101	415	300	400	322.0	419.0	0.6245
LCR 32/14-2	1525	2171	415	300	400	325.0	422.0	0.6245
LCR 32/14	1525	2171	415	300	400	325.0	422.0	0.6245

Performance Curves

Vertical multistage centrifugal pumps

LCR 32

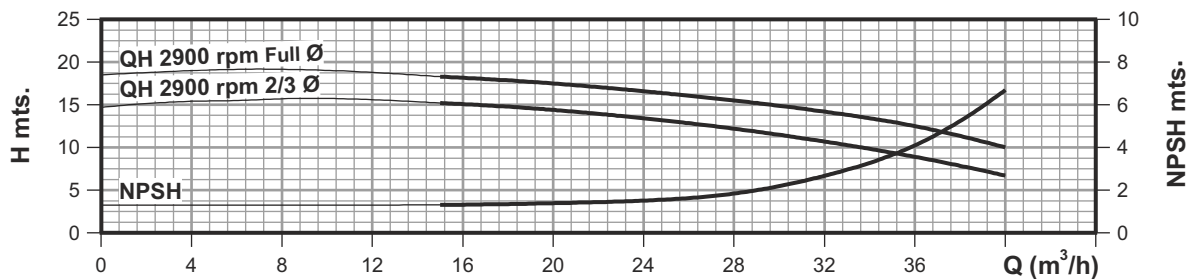
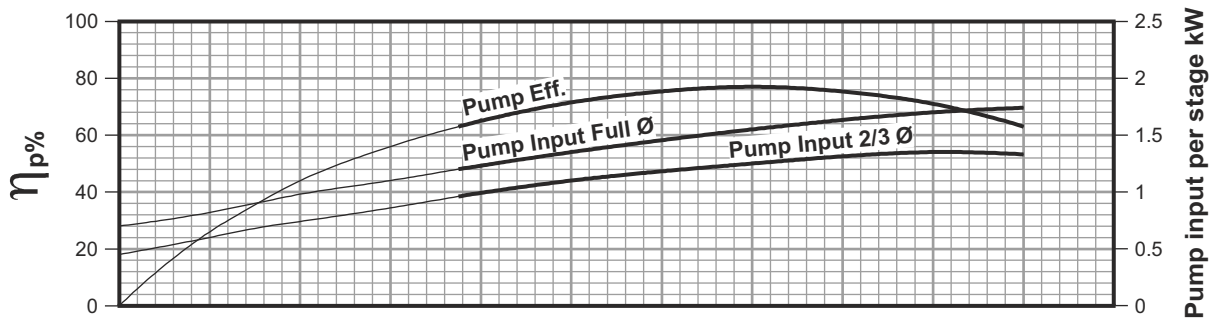
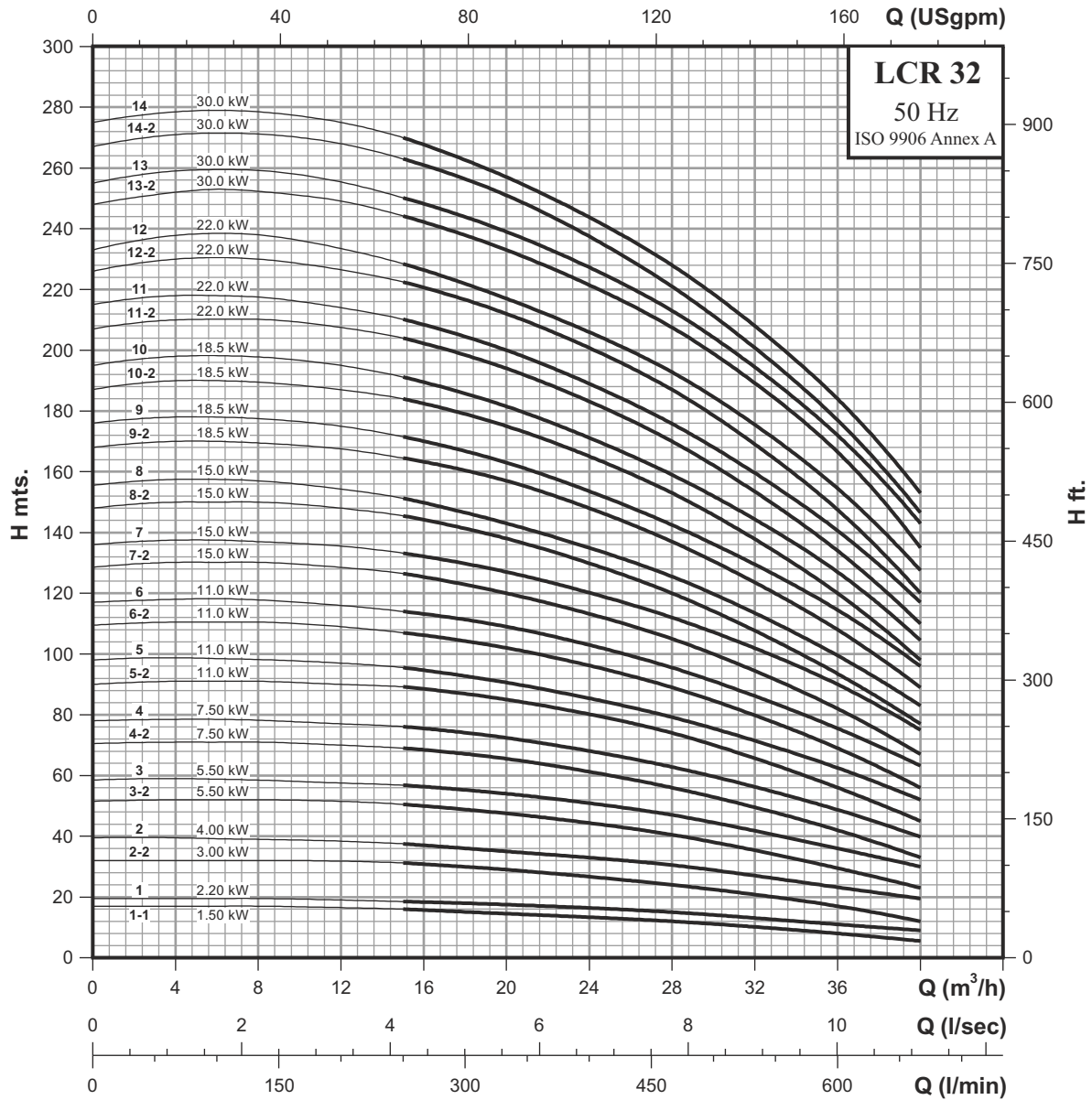

Technical Data

Vertical multistage centrifugal pumps

LCRI, LCRN 32

Performance Chart

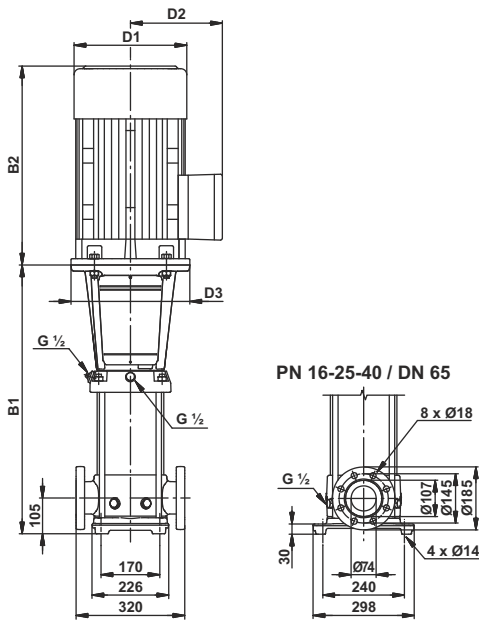

Pump Type	H.P.	kW	Q l/min m ³ /h	n = 2900 rpm					
				250.0	333.3	400.0	466.7	533.3	600.0
				15.0	20.0	24.0	28.0	32.0	36.0
LCRI, LCRN 32/1-1	2.00	1.50	H mts.	16	15	13	12	10	8
LCRI, LCRN 32/1	3.00	2.20		19	18	16	15	13	11
LCRI, LCRN 32/2-2	4.00	3.00		31	29	26	24	21	17
LCRI, LCRN 32/2	5.50	4.00		38	35	33	31	27	23
LCRI, LCRN 32/3-2	7.50	5.50		51	48	44	41	36	30
LCRI, LCRN 32/3	7.50	5.50		57	54	51	47	42	36
LCRI, LCRN 32/4-2	10.0	7.50		69	66	61	56	50	42
LCRI, LCRN 32/4	10.0	7.50		76	72	68	63	56	49
LCRI, LCRN 32/5-2	15.0	11.0		89	85	80	74	66	56
LCRI, LCRN 32/5	15.0	11.0		96	91	85	79	72	63
LCRI, LCRN 32/6-2	15.0	11.0		107	102	96	89	79	69
LCRI, LCRN 32/6	15.0	11.0		114	109	103	96	86	76
LCRI, LCRN 32/7-2	20.0	15.0		127	120	113	105	94	82
LCRI, LCRN 32/7	20.0	15.0		133	127	120	112	102	90
LCRI, LCRN 32/8-2	20.0	15.0		146	138	130	120	108	94
LCRI, LCRN 32/8	20.0	15.0		151	143	135	126	113	100
LCRI, LCRN 32/9-2	25.0	18.5		165	157	148	137	123	108
LCRI, LCRN 32/9	25.0	18.5		172	163	153	143	130	115
LCRI, LCRN 32/10-2	25.0	18.5		184	175	165	153	137	120
LCRI, LCRN 32/10	25.0	18.5		191	182	171	159	144	127
LCRI, LCRN 32/11-2	30.0	22.0		204	194	183	170	153	134
LCRI, LCRN 32/11	30.0	22.0		210	200	188	176	159	141
LCRI, LCRN 32/12-2	30.0	22.0		223	212	200	187	168	148
LCRI, LCRN 32/12	30.0	22.0		229	217	206	193	176	155
LCRI, LCRN 32/13-2	40.0	30.0		244	233	221	208	188	167
LCRI, LCRN 32/13	40.0	30.0		250	239	227	213	194	172
LCRI, LCRN 32/14-2	40.0	30.0		263	251	237	221	200	177
LCRI, LCRN 32/14	40.0	30.0	270	257	244	228	208	184	

Dimensions & Weights of LCRI, LCRN Pump

Pump type	Dimensions [mm]					Net weight [kg]	Gross weight [kg]	Gross volume [m ³]
	DIN flange		D1	D2	D3			
	B1	B1+B2						
LCRI, LCRN 32/1-1	505	783	165	130	135	61.0	119.0	0.3745
LCRI, LCRN 32/1	505	783	165	130	135	62.0	120.0	0.3745
LCRI, LCRN 32/2-2	575	879	194	140	-	76.0	134.0	0.3745
LCRI, LCRN 32/2	575	925	220	150	158	87.0	145.0	0.3745
LCRI, LCRN 32/3-2	645	1055	262	177	298	107.0	165.0	0.3745
LCRI, LCRN 32/3	645	1055	262	177	298	107.0	165.0	0.3745
LCRI, LCRN 32/4-2	715	1125	262	177	298	117.0	175.0	0.3745
LCRI, LCRN 32/4	715	1125	262	177	298	117.0	175.0	0.3745
LCRI, LCRN 32/5-2	895	1437	304	225	350	155.0	225.0	0.4495
LCRI, LCRN 32/5	895	1437	304	225	350	155.0	225.0	0.4495
LCRI, LCRN 32/6-2	965	1507	304	225	350	158.0	228.0	0.4495
LCRI, LCRN 32/6	965	1507	304	225	350	158.0	228.0	0.4495
LCRI, LCRN 32/7-2	1035	1577	304	225	350	175.0	245.0	0.4495
LCRI, LCRN 32/7	1035	1577	304	225	350	175.0	245.0	0.4495
LCRI, LCRN 32/8-2	1105	1647	304	225	350	178.0	248.0	0.4495
LCRI, LCRN 32/8	1105	1647	304	225	350	178.0	248.0	0.4495
LCRI, LCRN 32/9-2	1175	1717	304	225	350	211.0	294.0	0.5370
LCRI, LCRN 32/9	1175	1717	304	225	350	211.0	294.0	0.5370
LCRI, LCRN 32/10-2	1245	1787	304	225	350	214.0	297.0	0.5370
LCRI, LCRN 32/10	1245	1787	304	225	350	214.0	297.0	0.5370
LCRI, LCRN 32/11-2	1315	1925	363	262	350	250.0	333.0	0.5370
LCRI, LCRN 32/11	1315	1925	363	262	350	250.0	333.0	0.5370
LCRI, LCRN 32/12-2	1385	1995	363	262	350	254.0	337.0	0.5370
LCRI, LCRN 32/12	1385	1995	363	262	350	254.0	337.0	0.5370
LCRI, LCRN 32/13-2	1455	2101	415	300	400	322.0	419.0	0.6245
LCRI, LCRN 32/13	1455	2101	415	300	400	322.0	419.0	0.6245
LCRI, LCRN 32/14-2	1525	2171	415	300	400	325.0	422.0	0.6245
LCRI, LCRN 32/14	1525	2171	415	300	400	325.0	422.0	0.6245

Performance Curves

Vertical multistage centrifugal pumps

LCRI, LCRN 32

