

Submersible Rewindable Motor

4" WF Standard

Quality for your borewell :

These motors are water filled submersible motors which are designed and sized for installation in 4" diameter or larger water wells. Motors are designed so that they can be easily rewound and repaired. They are high torque capacitor start and run design.

Product Features :

- 4" Water filled submersible motor.
- Easily rewindable (wet wound) induction motor with PE insulated windings.
- Corrosion resistant stainless steel stator jacket and shaft.
- Water lubricated radial and axial thrust bearings.
- Counter thrust bearing.
- Motors are pre-filled with clean water + Glycol mixture.
- High efficiency electrical design (lower operating cost).
- Tropicalized design (lower winding temperature).
- Single phase motors are capacitor start and run design.
All single phase motors will require control box.
- Pressure compensation diaphragm.

Specifications :

- Ratings: Single phase - 0.37 to 4 kW
Three phase - 0.37 to 5.5 kW
- Supply voltages (Tolerance +6% / -10%):
50 Hz, 1 phase, 220 V, 230 V
50 Hz, 3 phase, 380 V, 400 V, 415 V
60 Hz, 1 phase, 115 V, 230 V
60 Hz, 3 phase, 230 V, 380 V, 460 V
- Degree of protection: IP 68
- Continuous duty
- Ambient temperature: 45°C
- Rotation: Single phase - CCW
Three phase - CCW and CW
- Maximum nos. of starts/hour:
0.37 to 2.2 kW - 20
3 to 5.5 kW - 10
- Water pH: 6.5 - 8
- Minimum cooling flow along the motor: 8 cm/sec
- Motor protection: Select thermal overload protection with trip time < 10 sec. at 5 x I_n
- Maximum submerged depth: 350 metres.

On Request :

- Special voltages.

Cable Data :

HP	Type of start	Cable x Leads x Size (mm ²)	Length [m]	H x B [mm]	
Single phase					
0.5 to 1.0	DOL	1 x 4 x 1.5	2.5	6 x 15.8	
1.5 to 5.5		1 x 4 x 2.5	2.5	6.5 x 18	
Three phase					
0.5 to 3.0	DOL	1 x 4 x 1.5	2.5	6 x 15.8	
4.0 to 7.5		1 x 4 x 2.5	2.5	6.5 x 18	



Submersible Rewindable Motor

4" WF Standard

Motors that are top class in Performance & Reliability

Cable

Cable safe for drinking water.

Earth cable

Outside earth cable provided.

Shaft Extension

Stainless steel splined shaft extension to NEMA

Shaft seal

Lip seal is standard.

Windings

Rewindable motor construction allows for low – cost motor repair that can be done locally.

Easy Maintenance

Designed for easy disassembly & repair

Efficiency

High efficiency provides energy saving.

Contamination

Water filled motor design prevents water contamination.

Thrust

The thrust bearing is larger than the competition and is rated to take much more thrust load than what would be subjected by the pump.

Corrosion

Water resistance CED coating used for corrosion resistance.

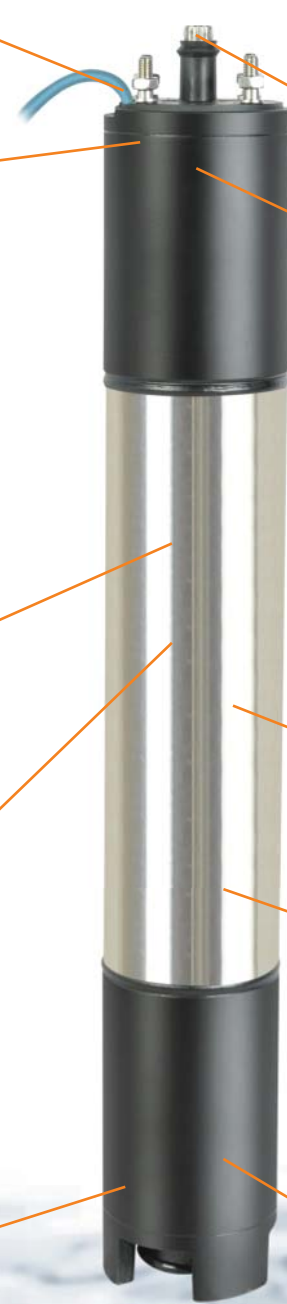

Submersible Rewindable Motor

4" WF Standard

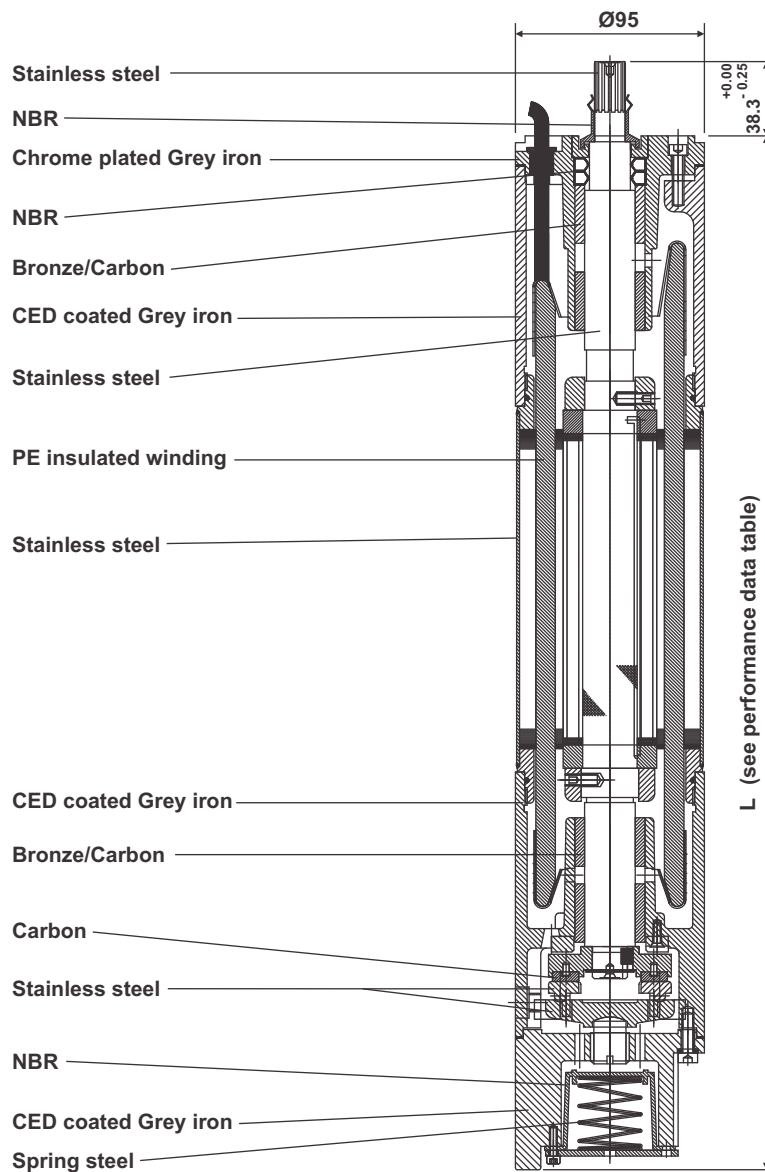
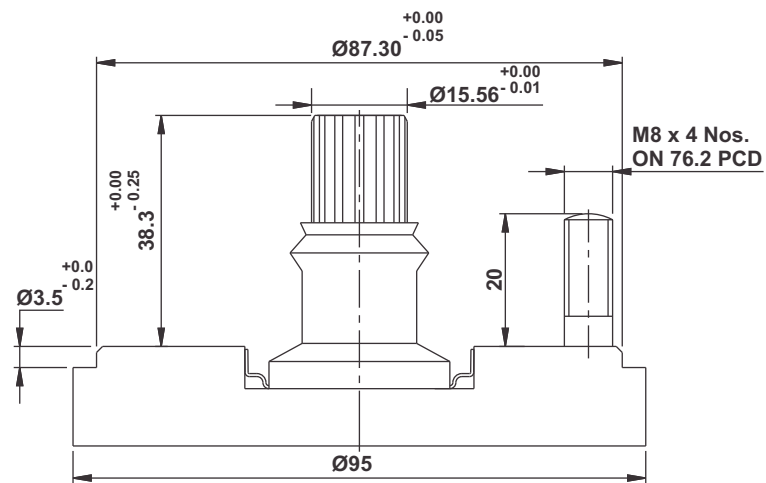

Shaft :

Spline shaft: 14 teeth, 24/48 pitch, 30° pressure angle, coupling tolerance 5 as per ANSI B.92.1, confirming with NEMA 4".

Submersible Rewindable Motor

4" WF Standard

4" Submersible Rewindable Motor Performance Data 50 Hz

Performance data

Motor type	Pn		Ka [N]	Un [V]	In [A]	Ist/In	n [min ⁻¹]	η [%]			COS φ			Tn [Nm]	L [mm]	Gross weight [kg]	Gross volume [m ³]
	kW	HP						50%	75%	100%	50%	75%	100%				
Single phase																	
L4505	0.37	0.50	4000	220	3.30	3.45	2820	51.0	55.0	57.0	0.79	0.81	0.83	1.23	431	14.3	0.0094
				230	3.44	3.50	2820	51.0	55.0	57.0	0.79	0.81	0.82	1.23			
L4507	0.55	0.75	4000	220	4.50	3.50	2820	55.0	60.0	62.0	0.80	0.81	0.82	1.83	446	15.2	0.0094
				230	4.70	3.60	2820	56.0	60.0	62.0	0.79	0.81	0.82	1.83			
L4510	0.75	1.00	4000	220	6.00	3.62	2820	59.0	64.0	65.0	0.79	0.81	0.82	2.50	456	16.7	0.0094
				230	6.12	3.68	2820	60.0	64.0	65.0	0.79	0.81	0.82	2.50			
L4515	1.10	1.50	4000	220	8.30	3.70	2820	61.0	66.0	67.0	0.82	0.84	0.85	3.67	511	19.1	0.0094
				230	8.40	3.80	2820	62.0	66.0	67.0	0.82	0.84	0.85	3.67			
L4520	1.50	2.00	4000	220	10.40	3.90	2820	61.0	69.0	71.0	0.83	0.86	0.87	5.02	611	22.6	0.0117
				230	10.56	4.00	2820	62.0	69.0	71.0	0.83	0.86	0.87	5.02			
L4530	2.20	3.00	4000	220	14.60	4.00	2820	63.0	69.0	72.0	0.86	0.88	0.90	7.38	711	26.4	0.0147
				230	14.76	4.10	2820	64.0	69.0	72.0	0.86	0.88	0.90	7.38			
L4555	4.00	5.50	4000	220	24.60	4.00	2800	63.0	69.0	72.0	0.85	0.88	0.90	8.10	841	30.3	0.0147
				230	24.83	4.10	2800	64.0	69.0	72.0	0.86	0.88	0.90	8.10			
Three phase																	
L4505-T	0.37	0.50	4000	380	1.30	3.90	2820	55.0	61.0	63.0	0.67	0.71	0.73	1.22	441	16.0	0.0094
				400	1.20	4.00	2820	56.0	61.0	63.0	0.68	0.72	0.74	1.22			
				415	1.10	4.05	2820	56.0	61.0	63.0	0.68	0.72	0.74	1.22			
L4507-T	0.55	0.75	4000	380	1.80	4.05	2820	56.0	62.0	64.0	0.68	0.72	0.75	1.82	456	16.8	0.0094
				400	1.70	4.10	2820	57.0	62.0	64.0	0.69	0.73	0.77	1.82			
				415	1.57	4.12	2820	57.0	62.0	64.0	0.70	0.74	0.76	1.82			
L4510-T	0.75	1.00	4000	380	2.20	4.10	2820	61.0	66.0	67.0	0.69	0.73	0.75	2.50	471	17.6	0.0094
				400	2.10	4.15	2820	62.0	66.0	67.0	0.70	0.74	0.76	2.50			
				415	2.05	4.22	2820	62.0	66.0	67.0	0.70	0.74	0.76	2.50			
L4515-T	1.10	1.50	4000	380	3.00	4.15	2820	65.0	70.0	71.0	0.70	0.71	0.76	3.69	521	20.3	0.0117
				400	2.90	4.20	2820	66.0	70.0	71.0	0.71	0.72	0.77	3.69			
				415	2.80	4.25	2820	66.0	70.0	71.0	0.71	0.75	0.77	3.69			
L4520-T	1.50	2.00	4000	380	3.90	4.28	2810	66.0	70.0	72.0	0.70	0.75	0.77	5.03	571	22.5	0.0117
				400	3.80	4.30	2810	67.0	70.0	72.0	0.71	0.76	0.78	5.03			
				415	3.72	4.33	2810	67.0	70.0	72.0	0.71	0.76	0.78	5.03			
L4530-T	2.20	3.00	4000	380	5.40	4.40	2800	67.0	73.0	74.0	0.73	0.77	0.79	7.40	671	25.5	0.0147
				400	5.30	4.45	2800	68.0	73.0	74.0	0.74	0.78	0.80	7.40			
				415	5.17	4.50	2800	68.0	73.0	74.0	0.74	0.78	0.80	7.40			
L4540-T	3.00	4.00	4000	380	7.20	4.40	2800	68.0	74.0	75.0	0.74	0.78	0.79	10.09	751	29.5	0.0147
				400	7.10	4.50	2800	69.0	74.0	75.0	0.75	0.79	0.80	10.09			
				415	6.96	4.60	2800	69.0	74.0	75.0	0.75	0.79	0.80	10.09			
L4555-T	4.00	5.50	4000	380	10.26	4.55	2800	68.0	74.0	75.0	0.75	0.78	0.79	13.45	821	33.4	0.0147
				400	9.62	4.60	2800	69.0	74.0	75.0	0.76	0.79	0.80	13.45			
				415	9.27	4.80	2800	69.0	74.0	75.0	0.76	0.79	0.80	13.45			
L4575-T	5.50	7.50	4000	380	14.10	4.75	2800	69.0	74.0	75.0	0.75	0.78	0.79	18.50	891	34.3	0.0147
				400	13.23	4.80	2800	70.0	74.0	75.0	0.76	0.79	0.80	18.50			
				415	12.75	5.00	2800	70.0	74.0	75.0	0.76	0.79	0.80	18.50			

Pn: Rated output
 Ka: Thrust load
 Un: Rated voltage
 In: Rated current
 Ist/In: Locked rotor current/Rated amperage
 n: Rated speed
 η: Efficiency
 cos φ: Power factor
 Tn: Rated torque
 L: Motor length

Submersible Rewindable Motor

4" WF Standard

4" Submersible Rewindable Motor Performance Data 60 Hz

Performance data

Motor type	Pn		Ka [N]	Un [V]	In [A]	Ist/In	n [min ⁻¹]	η [%]			COS φ			Tn [Nm]	L [mm]	Gross weight [kg]	Gross volume [m ³]
	kW	HP						50%	75%	100%	50%	75%	100%				
Single phase																	
L4605	0.37	0.50	4000	115	9.00	4.90	3450	51.0	56.0	58.0	0.81	0.84	0.86	1.23	431	14.3	0.0094
				230	4.40	4.90	3450	52.0	56.0	58.0	0.79	0.85	0.87	1.23			
L4607	0.55	0.75	4000	115	11.00	4.90	3450	52.0	56.0	58.0	0.80	0.84	0.86	1.83	446	15.2	0.0094
				230	5.50	4.90	3450	53.0	56.0	58.0	0.80	0.85	0.87	1.83			
L4610	0.75	1.00	4000	115	13.40	5.00	3450	52.0	56.0	59.0	0.79	0.81	0.83	2.50	456	16.7	0.0094
				230	6.66	5.00	3450	53.0	56.0	59.0	0.79	0.81	0.83	2.50			
L4615	1.10	1.50	4000	115	18.00	5.10	3450	61.0	66.0	67.0	0.81	0.87	0.88	3.67	511	19.1	0.0094
				230	9.00	5.10	3450	62.0	65.0	67.0	0.82	0.87	0.88	3.67			
L4620	1.50	2.00	4000	115	21.60	5.15	3450	61.0	66.0	68.0	0.82	0.86	0.89	5.02	611	22.6	0.0117
				230	10.78	5.15	3450	62.0	66.0	68.0	0.83	0.87	0.89	5.02			
L4630	2.20	3.00	4000	115	31.00	5.25	3450	63.0	69.0	72.0	0.85	0.89	0.91	7.38	711	26.4	0.0147
				230	15.50	5.25	3450	64.0	69.0	71.0	0.86	0.89	0.91	7.38			
L4655	4.00	5.50	4000	115	53.00	5.30	3450	65.0	70.0	72.0	0.86	0.92	0.95	8.10	841	30.3	0.0147
				230	26.50	5.30	3450	66.0	70.0	72.0	0.86	0.95	0.95	8.10			
Three phase																	
L4605-T	0.37	0.50	4000	230	2.30	4.20	3450	59.0	61.0	65.0	0.62	0.65	0.68	1.22	441	16.0	0.0094
				380	1.30	4.50	3450	59.0	61.0	65.0	0.64	0.68	0.71	1.22			
				460	1.20	4.50	3450	59.0	61.0	65.0	0.63	0.66	0.68	1.22			
L4607-T	0.55	0.75	4000	230	3.40	4.30	3450	56.0	6.0	64.0	0.68	0.72	0.75	1.82	456	16.8	0.0094
				380	1.95	4.70	3450	57.0	62.0	64.0	0.69	0.73	0.77	1.82			
				460	1.66	4.80	3450	59.0	62.0	66.0	0.65	0.69	0.70	1.82			
L4610-T	0.75	1.00	4000	230	4.20	4.30	3450	58.0	63.0	65.0	0.69	0.72	0.72	2.50	471	17.6	0.0094
				380	2.50	4.70	3450	59.0	64.0	66.0	0.70	0.73	0.73	2.50			
				460	1.95	4.80	3450	60.0	65.0	67.0	0.69	0.72	0.72	2.50			
L4615-T	1.10	1.50	4000	230	5.40	4.35	3450	62.0	67.0	71.0	0.68	0.71	0.73	3.69	521	20.3	0.0117
				380	3.20	4.75	3450	62.0	37.0	71.0	0.69	0.73	0.74	3.69			
				460	2.66	4.85	3450	62.0	67.0	71.0	0.68	0.71	0.73	3.69			
L4620-T	1.50	2.00	4000	230	7.20	4.85	3450	63.0	69.0	71.0	0.71	0.76	0.74	5.03	571	22.5	0.0117
				380	3.90	4.85	3450	63.0	69.0	72.0	0.72	0.78	0.76	5.03			
				460	3.58	4.88	3450	63.0	69.0	71.0	0.71	0.76	0.74	5.03			
L4630-T	2.20	3.00	4000	230	10.20	4.90	3450	67.0	70.0	73.0	0.71	0.73	0.74	7.40	671	25.5	0.0147
				380	5.40	4.90	3450	68.0	71.0	74.0	0.73	0.75	0.76	7.40			
				460	5.11	4.90	3450	67.0	70.0	73.0	0.71	0.73	0.74	7.40			
L4640-T	3.00	4.00	4000	230	13.20	4.85	3450	69.0	72.0	74.0	0.74	0.76	0.77	10.09	721	28.0	0.0147
				380	7.10	4.90	3450	70.0	73.0	75.0	0.75	0.77	0.78	10.09			
				460	6.61	4.95	3450	69.0	72.0	74.0	0.74	0.86	0.77	10.09			
L4655-T	4.00	5.50	4000	230	17.62	5.20	3450	70.0	73.0	74.0	0.72	0.75	0.77	13.45	821	33.4	0.0147
				380	9.70	5.18	3450	70.0	73.0	74.0	0.73	0.70	0.78	13.45			
				460	8.81	5.20	3450	70.0	73.0	74.0	0.72	0.75	0.77	13.45			
L4675-T	5.50	7.50	4000	230	24.55	5.20	3450	69.0	74.0	75.0	0.72	0.74	0.75	18.50	891	34.3	0.0147
				380	13.93	5.30	3450	70.0	74.0	75.0	0.76	0.79	0.80	18.50			
				460	12.27	5.35	3450	70.0	74.0	75.0	0.72	0.74	0.75	18.50			

Pn: Rated output
 Ka: Thrust load
 Un: Rated voltage
 In: Rated current
 Ist/In: Locked rotor current/Rated amperage
 n: Rated speed
 η: Efficiency
 cos φ: Power factor
 Tn: Rated torque
 L: Motor length